



Moldova

**REQUEST FOR QUOTATION (RFQ)**

NAME & ADDRESS OF FIRM:	DATE: <b>March 16, 2009</b>
	REFERENCE: <i>2009-03-16.2</i>

Dear Sir / Madam:

You are kindly requested to submit your quotation for the following items before 16:30 (local time) on **March 27, 2009**.

Item	Generic Description [incl. Technical specifications, quality & safety standards, special features required]	Quantity	Dimensions, mm
1	Computer desk with sliding shelf and bedside-table, PAL thickness - 18 mm, ABS	6	1380*670*750
2	Computer desk with sliding shelf, PAL thickness - 18 mm, ABS	7	670*500*750
3	Table, PAL thickness - 18 mm, ABS	4	1200*600*750
5	Conference table made of several pliable modules, PAL thickness - 18 mm, ABS	1	3000*1400*750
6	Ergonomic arm-chair	6	
7	Visitor's chair	30	
8	Bookshelves (with glass doors)	8	800*400*1900
9	Wardrobe, 2 doors -2 partitions (1 partition with shelves, 1 partition with rack and one shelf)	4	1200*600*2100
10	Rack	6	
11	Kitchen table (water and temperature resistant cover)	1	1500*900*750
12	Set of kitchen furniture, PAL thickness - 18 mm, ABS	1	3 linear meters
13	Kitchen stools	8	
14	Bed (adult) with straight corners, back and incorporated drawers, PAL thickness - 18 mm, ABS	6	1900*900*650
15	Bed (adult) with straight corners, PAL thickness - 18 mm, ABS	2	1900*900*650
16	Mattress	8	1900*900*180
17	Bed-side table, PAL thickness - 18 mm, ABS	8	450*450*650

CONDITIONS	
Delivery Term (INCOTERMS 2000) & Place	<input type="checkbox"/> FCA <input type="checkbox"/> CPT <input checked="" type="checkbox"/> CIP
Delivery Place	Social Reintegration Centre for Youth located on 14, Ion Voda str. (Kindergarten No.4, Bloc B), town of Telenesti
Payment Terms	20% payment upon contract signature 80% upon delivery of final product
Validity of Quotation	<input type="checkbox"/> 30 DAYS <input checked="" type="checkbox"/> 60 DAYS
Preliminary Examination - Completeness of quotation.	<input type="checkbox"/> Partial bids permitted <input checked="" type="checkbox"/> Partial bids not permitted

*oc*

Mode of Transport	AIR	SEA
	SURFACE	OTHERS
Quantity change	<b>The UNDP reserves the right to modify the quantity by 25% of the tendered goods</b>	
General Terms and Conditions	UNDP General Terms and Conditions for Goods/Services <a href="http://www.undp.org/procurement/operate.shtml">http://www.undp.org/procurement/operate.shtml</a>	

<b>Please state</b>	
Quantity discount and early payment discount	Shipping weight (kg) and volume (m <sup>3</sup> )
Separate quote for estimated transportation & insurance charges	Details on delivery period:
In case when color may influence the final price, please specify the price differences	
Details on any warranty/guarantee conditions:	

<b>REQUIREMENTS</b>	
<u>Language:</u> All documentation, including installation and operating manuals shall be in:	
<input checked="" type="checkbox"/> English <input type="checkbox"/> French <input type="checkbox"/> Spanish <input checked="" type="checkbox"/> Others: Romanian	
Electricity: Volt: _____ Hz: _____ phase AC: _____	
<b>QUOTATIONS/OFFERS PRESENTATION REQUIREMENTS:</b>	
The quotation/offer shall contain the following:	
<ul style="list-style-type: none"> <li>• Company profile (in brief);</li> <li>• Copy of Company's registration certificate;</li> <li>• Quotation for each item in MDL exclusive of VAT (other currency shall be converted in MDL at the UN Operational Rate of exchange on the day of the competition deadline);</li> <li>• Statement of adherence to UNDP General Terms and Condition and Payment and Delivery Terms above;</li> <li>• Your proposal shall include any relevant drawing and specification.</li> </ul>	
<b>MINIMUM QUALIFICATION REQUIREMENTS:</b>	
<ul style="list-style-type: none"> <li>• Delivery term will not exceed 14 calendar days.</li> <li>• Furniture to be manufactured by an authorized company, holder of appropriate license and documentation. Copies of authorizations to be attached to tender participation documents.</li> <li>• Warranty – not less than 18 months.</li> </ul>	
Offers will be evaluated based on their responsiveness to the technical specifications and the minimum qualification requirements, within the "either in or out" rule.	

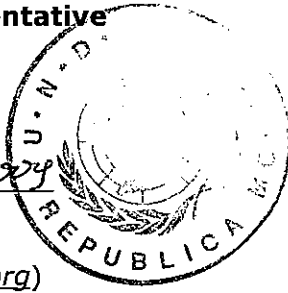
NAME, FUNCTIONAL TITLE: <b>Matilda Dimovska, Deputy Resident Representative</b>	
Signature: 	DATE: <u>16.03.2009</u>
	
CONTACT PERSON: <i>Liliana Caterov, Project Assistant</i> ( <a href="mailto:liliana.caterov@undp.org">liliana.caterov@undp.org</a> )	
CONTACT ADDRESS: UNDP Moldova, 131, 31 August 1989 Street, MD-2012 Chisinau	
<b>SUBMISSION OF OFFERS:</b>	
Offers shall be marked with the note " <b>RfQ: BO Project – Furniture for SRCY Telenesti</b> ".	
Offers shall reach the UNDP office not later than <b>27 March 2009, 16:30 (local time)</b> .	

Offers can be submitted either in hard copy, or electronically. Offers received by fax will be rejected. Incomplete offers shall not be examined.

- a) Documents/offers in hard copy need to be submitted in a sealed envelope and addressed to:  
**UNDP Moldova,**  
**131, 31 August 1989 Street, MD-2012 Chisinau**  
**Attention: Registry Office/Procurement**
- b) Offers sent electronically need to be addressed to the following e-mail address:  
**tenders-Moldova@undp.org**

Computer desk with sliding shelf and bedside-table

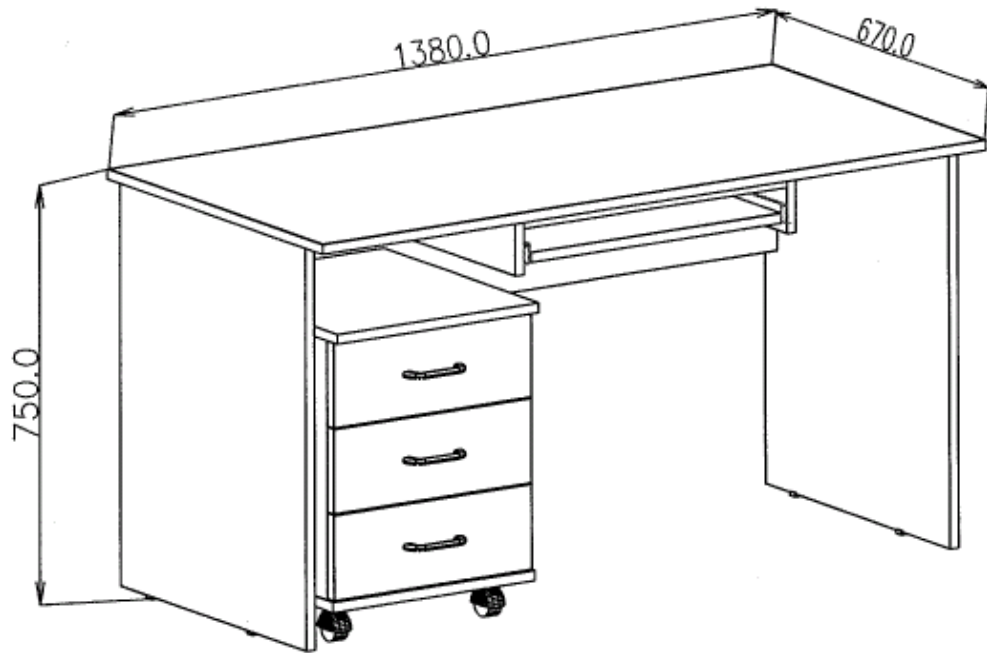

Bookshelves (with glass doors)

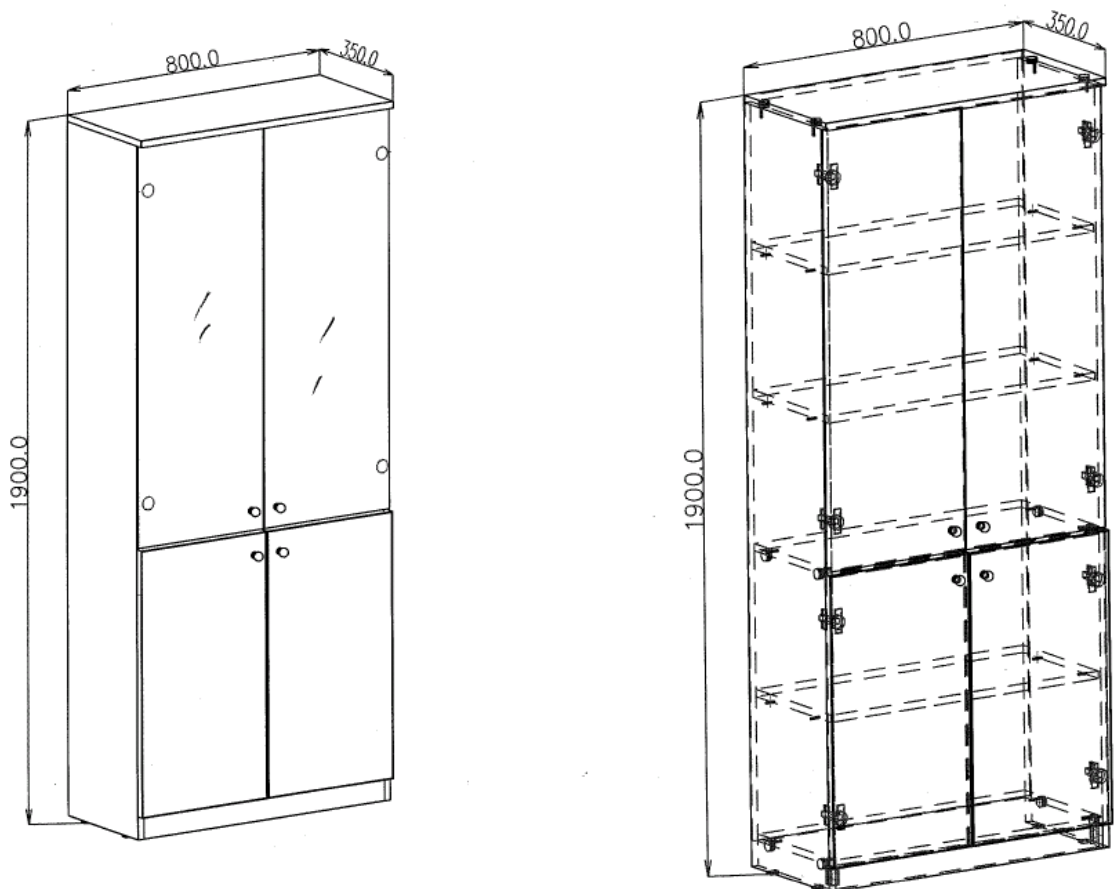

**Kitchen table (water and temperature resistant cover)**

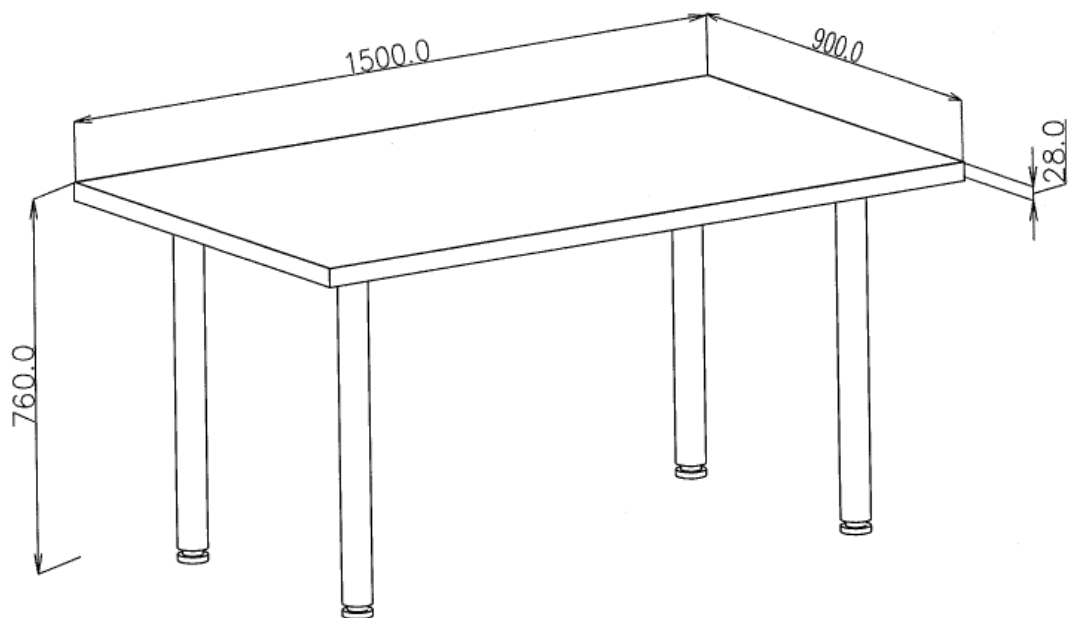

**Bed (adult) with back and incorporated drawers and straight corners (not rounded)**

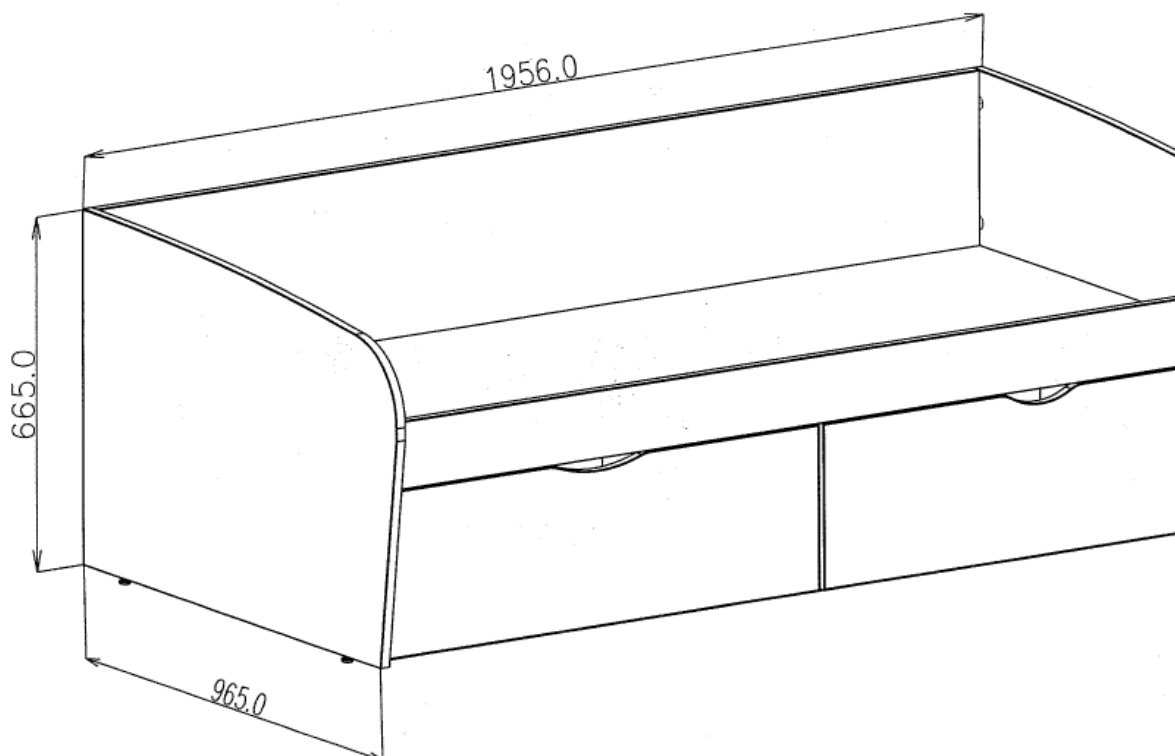

Bed-side table

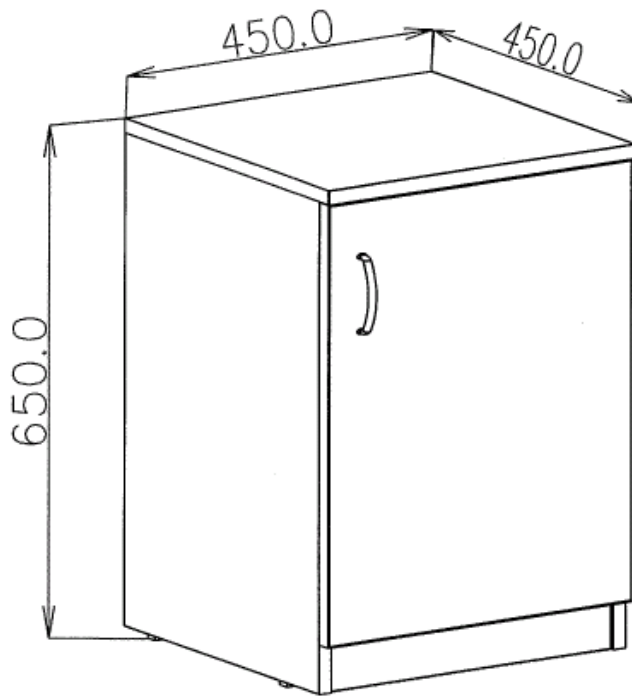

Table

